



Find out about our special offer
on <https://biosan.lv/classes-en>



IW-8

Intelspeed Washer



User instructions

If you have any feedback on our products or services, we would like to hear from you.
Please send all feedback to:

Manufacturer:

SIA Biosan
Ratsupites 7 k-2, Riga, LV-1067, Latvia

Phone: +371 674 261 37

Fax: +371 674 281 01

<https://biosan.lv>

Marketing: marketing@biosan.lv

Service: service@biosan.lv

Contents

1.	About this edition of user instructions.....	3
2.	Safety precautions	4
3.	General information.....	6
4.	Getting started.....	7
5.	Operation	12
6.	Operation shutdown	17
7.	Specifications	18
8.	Ordering information	19
9.	Care and maintenance	20
10.	Storage and transportation.....	23
11.	Warranty.....	24
12.	EU declaration of conformity	25

1. About this edition of user instructions

1.1 The current edition of the user instructions applies to the following models:

Model and name	Version
IW-8, intelispeed washer	V.6AW

1.2 Edition 6.01 – December of 2023.

2. Safety precautions

2.1 Symbols used in these instructions:



Caution! Please make sure you have fully read and understood current instructions before using the equipment and pay special attention to sections marked by this symbol.

2.2 Icons used on the unit and packaging:

	CE marking, manufacturer affirms conformity with European health, safety, and environmental protection standards, see 12.1
	WEEE directive marking, see 12.1
	Polarity of the power connector
	Equipment uses direct current
	Warning: Always perform the rinsing cycle using distilled water and dry the system after operation. This will keep the unit in working order and prevent channel clogging.

2.3 General safety precautions

- The protection provided can be ineffective if the operation of the appliance does not comply with the manufacturer's requirements.
- Save the unit from shocks and falling.
- Store and transport the unit as described in section **Storage and transportation**.
- Use only original parts and accessories, provided by manufacturer for this product.
- Before using any cleaning or decontamination methods except those recommended by the manufacturer, check with the manufacturer that the proposed method will not damage the equipment.
- Do not make modifications in design of the unit.

2.4 Electrical safety

- Connect only to an external power supply with voltage corresponding to that on the serial number label.
- Use only the external power supply provided with this product.
- Do not plug the power supply into an ungrounded power socket, and do not use an ungrounded extension lead.
- Ensure that the switch and external power supply connector are easily accessible during use.
- Disconnect the unit from the mains before relocating it.
- If liquid penetrates into the unit, disconnect it from the mains and do not use it until it is checked by a repair and maintenance technician.
- Do not operate the unit in premises where condensation can form. Operating conditions of the unit are defined in section **Specifications**.

2.5 During operation



Note. If possible, do not use the plates with unevenly filled wells in a row, e.g. 4 empty, 4 filled. Otherwise, if encountering aspiration problems, consult with the troubleshooting guide (see Table 4 in 9.1.6, “Aspiration is not effective in an unevenly filled row of wells”).

- Do not operate the unit in environments with aggressive or explosive chemical mixtures. Please contact manufacturer for possible operation of the unit in specific atmospheres.
- Before changing the manifold, the bottles or the tubes, disconnect the unit from the mains.
- Do not operate the unit if it is faulty.
- Always have the cover protecting against aerosol spread (hereinafter protective cover) installed during operation.
- Do not operate the unit without the manifold installed.
- Do not operate the unit if any of the needles is clogged or malfunctions.
- Never touch the needles or place fingers or other parts under the needles during operation. Manifold needles are sharp and can cause injury.
- If liquid spills on the guiding rail, stop the operation, clean and wipe the surface dry.
- Do not allow the waste bottle to overflow the maximum level during operation (there is a mark on the side surface of the bottle). Take necessary precautions utilizing waste liquid in accordance with general laboratory standards.

2.6 After operation

- Carry out the cycle of system washing as described in section **Operation closedown**. This will keep the system in permanent operation condition.
- Clean the guiding rail under the platform and wipe it dry to prevent oxidation layer formation and to prolong working life of the unit.

2.7 Biological safety

- It is the user's responsibility to carry out appropriate decontamination if hazardous material is spilt on or penetrates into the equipment.
- In diagnostic research, potentially dangerous biological materials can be used. When working with such materials, always use protective clothing and eye protection. Always have the protective cover installed during operation.

3. General information

Intelispeed Washer **IW-8** is designed for washing of standard flat-bottom 96-well plates during IFA, etc., in diagnostical laboratories. IFA is also performed in other areas, including scientific research. The unit is fully programmable ensuring multi-step solution ripening, aspiration (aspiration, combination of aspiration/liquid dispensing and soaking, as well as soaking cycle during a particular period of time).

Standard version is supplied with 8-channel manifold for dispensing/aspiration, 3 channels with 3 bottles for washing and rinsing solutions and 2 bottles for waste and aerosol collecting.

The unit has 101 user-defined editable programs (from 00 to 100).

Optional 4-channel washing solution weight logger **4CHW Logger** is available. After connecting it to Intelispeed Washer IW-8, the unit provides automatic control of reagent total volume in all bottles that is necessary for washing and waste collecting and estimates the volume of reagents necessary for washing.

Microbiologic suction filter eliminates risks of contamination caused by bacteria, viruses, and infected particles from patient. Such contamination can be distributed by suction pump or central vacuum units. Microbiological suction filter is hydrophobic and has very high bacterial efficiency – up to 99.99% of particles bigger than 0.027 micrometres (which are smaller than Hepatitis A, B and C).

The unit includes:

- washing mode;
- rinsing mode;
- double aspiration;
- additional solution mixing (shaking) mode during time gap between two work cycles;
- soaking mode;
- possibility to use plates of different manufacturers. This is ensured by automated plate setup (adjusting to different depths of plate wells);
- round-bottom plate and strip washing mode;
- user-defined programs with adjustable parameters;
- automatic storing of work programs.

4. Getting started

- 4.1 **Unpacking.** Remove packing materials carefully and retain them for future shipment or storage of the unit. Examine the unit carefully for any damage incurred during transit. The warranty does not cover in-transit damage. Warranty covers only the units transported in the original package.
- 4.2 **Complete set.** Numbers in the first column correspond to numbers on Figure 1.

#	Name	Quantity
1	IW-8 Intelispeed washer	1 piece
2	Platform for plates	1 piece
3	Manifold	1 piece
4	Protecting cover	1 piece
5	External power supply	1 piece
6	Tubes (outside/inside diam./length 6/3/600 mm)	5 pieces
7	Tube for manifold (outside/inside diam./length 3.2/1.6/400 mm)	1 piece
8	Tube for manifold (outside/inside diam./length 5/3/440 mm)	1 piece
9	Tube for hydrophobic filter (outside/inside diam. 9/6 mm)	1 piece
10	Half-litre bottle with connectors for aerosol collection	1 piece
11	1-litre bottles with sieve filters and connectors for reagents	3 pieces
12	2-litre bottle with connector for collecting of waste liquid	1 piece
13	Hydrophobic filters for half-litre bottle	2 pieces
14	Manifold cleaning set	1 piece
15	Syringe for liquid flushing in hoses	1 piece
16	Power cable	1 piece
17	User instructions, declaration of conformity	1 copy
18	4-channel washing solution weight logger, 4CHW Logger (<i>on request</i>)	1 set

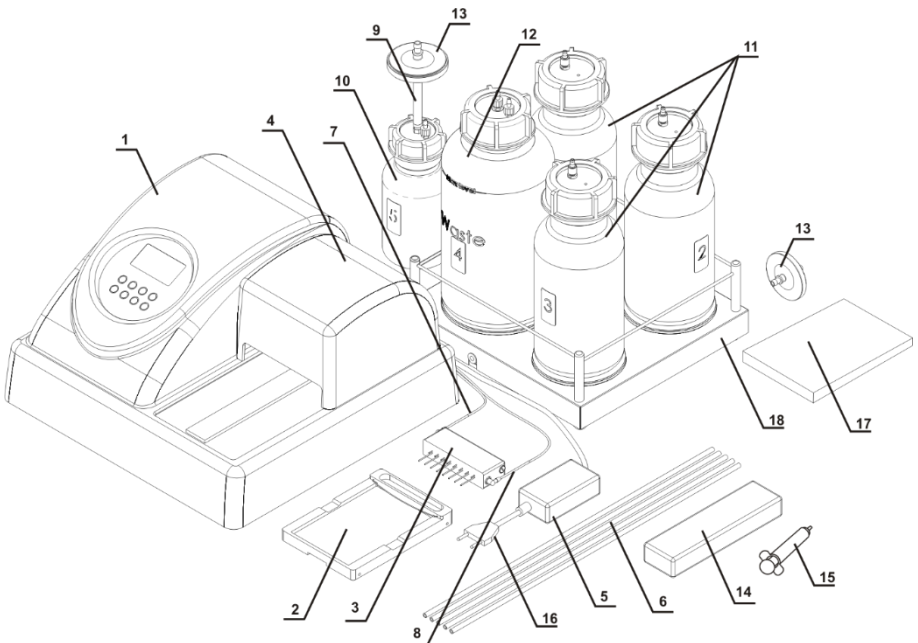

Figure 1. Complete set

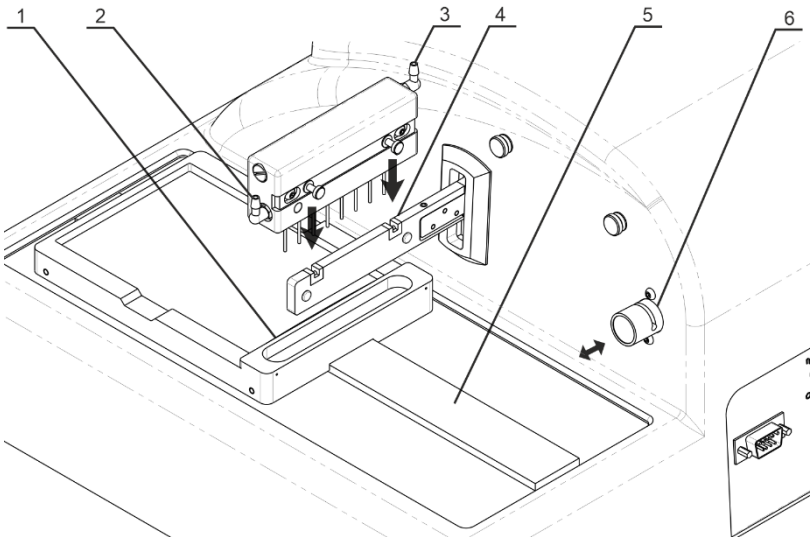

Figure 2. Unit side and back overview. Setting up.
1. Plate platform. 2. Wash head aspiration. 3. Wash head dispensing.
4. Holder arm with magnet guides. 5. Railing. 6. Valve.

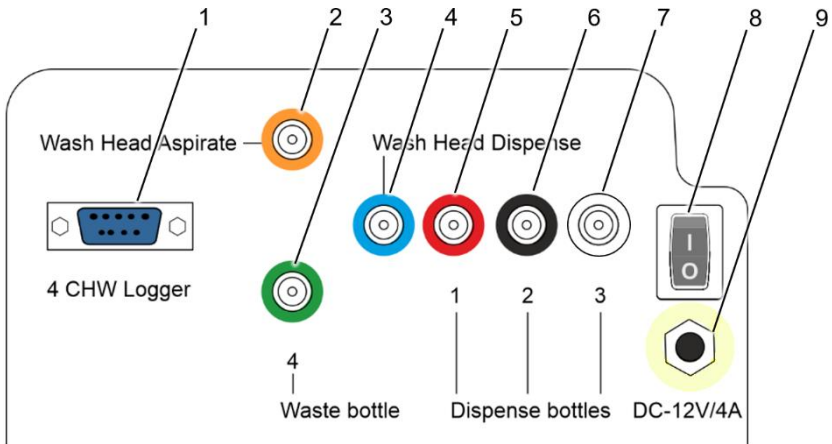

Figure 3. Rear panel

1. 4CHW Logger connector. 2. Wash Head aspiration input manifold.
 3. Waste bottle output manifold. 4. Wash Head dispensing output manifold.
 5-7. Dispense bottle input manifolds.
 8. Power switch. 9. Power cable socket.

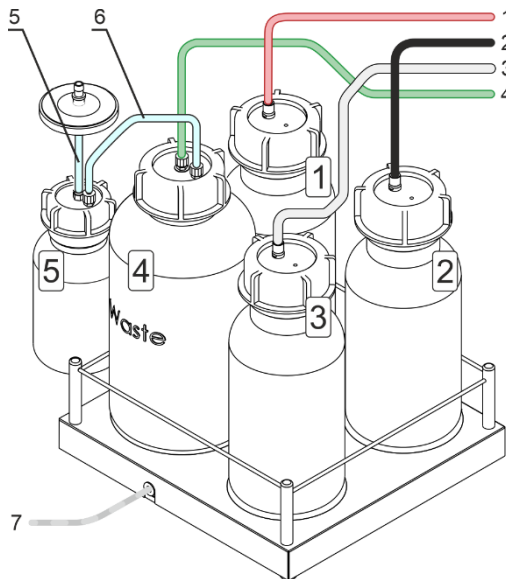

Figure 4. Bottles and tubing.

Bottles ##1-3 and tubes 1-3 with washing solutions.

Bottle #4 and tube 4 for liquid waste.

Bottle #5 and tube 5 for aerosol filtration, tube 6 to connect bottles #4 and #5.

Cable 7 to connect 4CHW Logger to the unit.

4.3 Setup.

4.3.1 Unit setup.

- Place the unit on a stable horizontal surface, which can safely support weight of the unit.
- To provide optimal ventilation, ensure 100 mm clearance on each side.
- Operating conditions are described in the **Specification** section.
- Remove the protecting cover from display.

4.3.2 Plate platform setup.

- Unpack the plate platform (fig. 1/2).
- Place the plate platform on the railing (fig. 2/5) so that the plate holder (flat spring) faces the rear side of the unit (fig. 2/1). Magnet on the other side of the rail locks the platform into start position.



Note. If the plate platform is installed improperly, the magnet does not hold it in place and the platform will be able to move freely. Move the platform along the railing until the magnets lock. Increase of resistance to movement indicates that the magnets are locked.

4.3.3 Manifold setup.



Caution! Be careful working with the manifold, prevent pricks and injuries caused by needles!

- Unpack the manifold.
- Install the manifold in the slots of the holder arm (fig. 2/4). Magnets in the manifold and the holder arm connect and align the manifold.

4.3.4 Connecting parts of the unit.



Note. All tubes (fig. 1/6–1/8) and fittings (fig. 3/2–3/7) are colour-coded. Ensure that the tubes are connected securely.

4.3.4.1 Manifold tubes.

- Align the thin tube with a blue stripe (fig. 1/7) with the slot on the upper side of the valve (fig. 2/6).
- Push the valve inside (fig. 2/↔), stretch and insert the tube through the slot.
- Release the valve.
- Connect tubes as described below

Tube	Connectable parts	
Thin tube with a blue stripe (fig. 1/7)	Wash head dispenser fitting, higher and closer to display (fig. 2/3)	Blue fitting Wash Head Dispense on the rear panel (fig. 3/4)
Thin tube with a yellow stripe (fig. 1/8)	Wash head aspiration, lower and farther from display (fig. 2/2)	Orange fitting Wash Head Aspirate on the rear panel (fig. 3/2)

- Install the protective cover (fig. 1/4). Ensure that manifold tubes are covered but are not squeezed.

4.3.4.2 Bottles.

- Place the bottles near the unit.
- If **4 CHW Logger** is in use, remove pads from underside of scale cups and arrange the bottles according to the numbers on scale cups.
- Connect the tubes and cables as follow:

Tube/cable	Connectable parts	
Tube with a green stripe (fig. 4/4)	Central fitting on the 2L bottle #4 (fig. 4)	Green fitting 4 – Waste bottle on the rear panel (fig. 3/3)
Tube w/o stripe (fig. 4/6)	Side fitting on the 2L bottle #4 (fig. 4)	Side fitting on the 0.5L bottle #5 (fig. 4)
Short wide tube w/o stripe (fig. 4/5)	Central fitting on the 0.5L bottle #5 (fig. 4)	Aspiration filter (fig. 2/13), side with the marking IN
Tube with a red stripe (fig. 4/1)	Fitting on the 1L bottle #1 (fig. 4)	Red fitting 1 – Dispense bottles on the rear panel (fig. 3/5)
Tube with a black stripe (fig. 4/2)	Fitting on the 1L bottle #2 (fig. 4)	Black fitting 2 – Dispense bottles on the rear panel (fig. 3/6)
Tube with a white stripe (fig. 4/3)	Fitting on the 1L bottle #3 (fig. 4)	White fitting 3 – Dispense bottles on the rear panel (fig. 3/7)
4 CHW Logger adapter cable (fig. 4/7, if in use)	4 CHW Logger connector on the rear panel (fig. 3/1)	

5. Operation

5.1 This section describes the following actions:

- Switching on and preparing the unit for operations.
- Microplate setup and unit calibration.
- Program choice and setup.
- Starting the chosen program.

5.2 **Switching on.**



Caution! Before connecting the unit to the mains outlet, check that the power switch (fig. 3/8) is in position **O** (off).

- Connect the external power supply to the power socket (fig. 3/9) on the rear panel of the unit.
- Connect the power cord to the external power supply (fig. 1/16)
- Connect the external power supply to the grounded power socket.
- Position the unit with easy access to the plug and the power switch.
- Switch on the unit (position **I**) using the power switch (fig. 3/8) on the rear panel.
- When switched on, the unit performs full initialisation cycle and displays the message "Power on reset" (figure 5)



Note. Full initialisation cycle takes no longer than 5 seconds.

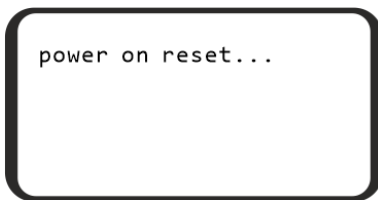

Figure 5. Initialisation screen

5.3 **Before starting plate washing:**

- Fill the rinsing liquid bottle (#3) with distilled water or appropriate cleansing solution.
- Fill the necessary bottles (#1 and/or #2) with washing solutions.

5.4 **Microplate installation.** Hold the plate platform in place with one hand and place the microplate on the plate platform on the other by pressing the flat spring on one side of the platform.



Caution! When installing a type of plate for the first time, perform the plate setup to adjust the manifold lowering depth (see paragraph 5.10).



Note. If possible, do not use the plates with unevenly filled wells in a row, e.g. 4 empty, 4 filled. Otherwise, if encountering aspiration problems, consult with the troubleshooting guide (see Table 4 in 9.1.6, "Aspiration is not effective in an unevenly filled row of wells").

5.5 **Plate setup.** When installing a plate for the first time or when a plate of different type is used, setup the lowering depth of the manifold's needles.

- Press the **Calibr.** ▼ key (fig. 7/4) in the program choosing mode, then the ►/■ key (fig. 7/7), and the following message appears on the display (figure 6).
- To calibrate, press the ►/■ key. The manifold measures the depth of the plate well by touching the plate surface first and then the bottom of the well. The unit saves the difference of the measured values.

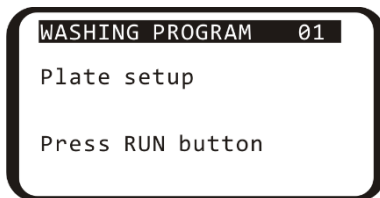

Figure 6. Plate setup

5.6 **Program selection and parameter edition.** All values are adjustable. User programs can be created by changing the template of the original program.

5.6.1 To navigate the menu:

- To select the program number from 00 to 100, use the + and – keys (fig. 7/6).
- To edit the program parameters, press the **Parameters / Save** key (fig. 7/1).
- When editing the program parameters, to change values of currently selected parameter use the + and – keys.
- When editing the program parameters, to select next or previous parameter use the **Calibr.** ▼ or **Row** ▲ keys (fig. 7/4 and 7/2).
- When editing the program parameters, to save and apply changes and exit the editing mode, press the **Parameters / Save** key.
- When editing the program parameters, to exit the editing mode without saving, press the **Esc** key (fig. 7/5).

5.6.2 In figure 8, unit is set to program 01 (top right corner) and is in the editing mode (Dispense ... YES is selected).

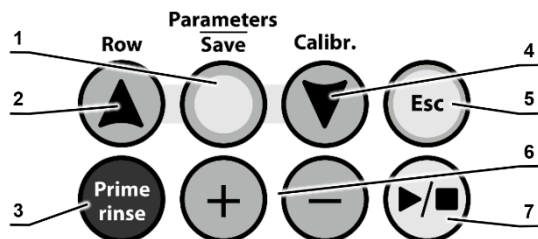

Figure 7. Control panel keys

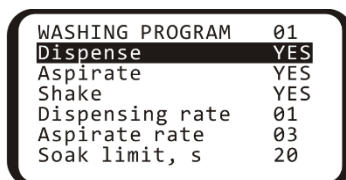

Figure 8. Program parameters

5.6.3 Initial parameters of all user programs are listed below in Table 1. Their range and description are listed below in Table 2.

Table 1. Initial parameters of all user programs.

Program #	00	01	02	03	04	05	06	07	08-100
Parameter	Aspirate	1x400_30	2x400_30	3x400_30	5x400_30	5+1x400_30	Soak 5 min.	Dispense 200	
Dispense	NO	YES	YES	YES	YES	YES	YES	YES	YES
Aspirate	YES	YES	YES	YES	YES	YES	YES	YES	YES
Shake	NO	NO	NO	NO	NO	NO	NO	NO	NO
Dispense rate	02	02	02	02	02	02	02	02	03
Aspirate rate	03	03	03	03	03	03	03	03	03
Soak time, s	20	30	30	30	30	30	300	00	00
Shake time, s	-	-	-	-	-	-	-	30	30
Double aspiration	YES	YES	YES	YES	YES	YES	YES	-	YES
Dispensed volume, µl	-	400	400	400	400	400	300	200	300
Aspiration time, ms	1200	600	600	600	600	600	600	-	1000
Final aspirate, ms	-	1200	1200	1200	1200	1200	1200	-	YES
First aspirate	-	YES	YES	YES	YES	YES	NO	-	YES
Wash by rows	-	YES	YES	YES	YES	YES	NO	-	YES
On two channels	-	NO	NO	NO	NO	YES	NO	-	NO
Num.of 1 wash cycles	-	01	02	03	05	05	01	-	03
1 channel	-	01	01	01	01	01	01	01	01
Num.of 2 wash cycles	-	-	-	-	-	01	-	-	-
2 channel	-	-	-	-	-	02	-	-	-

Table 2. Program parameters and their definitions

Parameter	Value or range	Description
Dispense	yes/no	Perform fill
Aspirate	yes/no	Perform aspiration ¹
Shake	yes/no	Plate shaking on the platform during the cycle
Dispense rate	01–03	Speed of liquid filling
Aspirate rate	01–03	Speed of liquid aspiration
Soak limit, s	0–300	Time between fill and aspiration, step 10 s
Shake limit, s	05–150	Shaking time, step 5 s
Double aspiration	yes/no	Second aspiration mode
Dispensed volume	25–1600	Volume of dispensed liquid, step 25 µl
Aspirate time, ms	200–3000 ms	Time of aspiration from well in cycle, step 200 ms
Final aspirate, s	200–3000 ms	Time of last aspiration in the cycle, step 200 ms
First aspirate	yes/no	Aspiration is the first action in a cycle
Wash by rows	yes/no	Each row is washed once per cycle
On two channels	yes/no	Use 2 washing solutions
Num.of wash cycles	01–15	Number of washes with first solution
1 channel	01–03	Number of bottle to use for the main washing
Second chan. cycles	01–15	Number of washes with second solution
2 channel	01–03	Number of bottle to use for the second washing



Note.

If some of the parameters from Tables 1 and 2 are set to NO, the associated items will not appear in the parameter change menu. For example, **Num.of 2 wash cycles** and **2 channel** only appear if **On two channels** is set to YES.

5.7 Running the program.

5.7.1 By default, the unit washes all rows of the microplate. In order to wash less rows, when in the program selection menu press **Row ▲** (fig. 7/2). Display shows the row count menu (figure 9). Using the **+** and **–** keys, set the necessary number of rows. To cancel and return to the previous menu, press **Esc**. To save and start the program, continue reading.

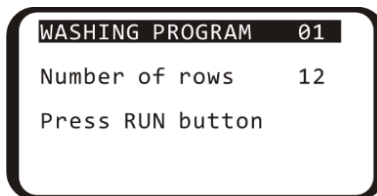

Figure 9. Row count selection menu

¹ During aspiration, the waste fluid bottle is detected automatically – bottle #4. The number is not specified on the display.

5.7.2 Press the ►/■ key (fig. 7/7) to start the program. The program can be started from the program selection menu, program parameters editing mode, or row count selection menu. To abort and return to program selection, press **Esc** key.

5.7.3 If the operation requires washing on two channels (parameter **On two channels** set to **YES**), then after starting the program, unit requests the confirmation of the correct bottle number for second wash. (figure 10) Select the necessary bottle number using + and – keys and press the ►/■ key.



Note. During transportation, internal pump can dry out and may fail to fetch liquid from the bottle. To fix this, consult the troubleshooting table in **9.1.6**, part “On starting the operation, the device does not fetch liquid from the active bottle”

5.8 **During operation.**

5.8.1 During operation, display (figure 11) shows the program number (**01**), number of the bottle in use (**1**), the current cycle (**03**) and the current timed action (**Shake . 05**).

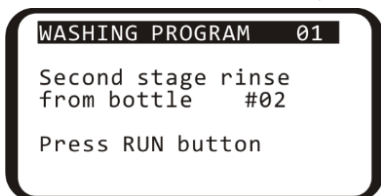

Figure 10. Second bottle confirmation

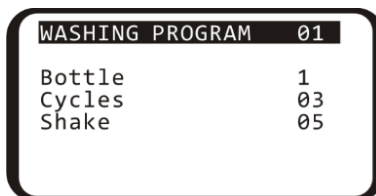

Figure 11. Running program

5.8.2 If **4 CHW Logger**, the 4-channel washing solution weight logger is connected to the unit, then in addition to values on figure 11, display shows percentage of the remaining volume of liquid in the bottles (figure 12). For the waste bottle #4, percentage values will be increasing.

5.9 To stop the program during operation, press the ►/■ key. The message **CANCELLED BY OPERATOR** appears on the lower line of the display. Press the ►/■ key to restart the operation.

5.10 When the cycle is completed, unit produces an informative sound signal. Proceed to the section **Operation closedown**.



Note. If in doubt as to whether the rinsing is complete and even, repeat the rinsing. The quality of the plate washing affects the validity of the results obtained from the test. To ensure that the washing procedure was performed correctly, make periodic visual checks of the reproducibility of the dispensed volumes.

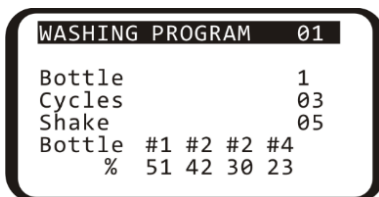

Figure 12. 4CHW Logger attached

6. Operation shutdown

6.1 This section describes the required water rinsing procedures before shutdown.

6.2 Rinsing the tubes.



Caution! Always perform the rinsing cycle using distilled water after finishing the operation at the end of working day. This will help to keep the unit in working order and prevent tube clogging.

6.2.1 Fill one of the bottles ##1–3 with distilled water.

6.2.2 Attach the rinsible tube to this bottle.

6.2.3 Press the **Prime rinse** (fig. 7/3), display shows the rinsing menu (figure 13). Select the channel of the attached tube using the + and – keys. Channel number can be found on the rear panel of the unit, under the attached tube (fig. 3/5–3/7)

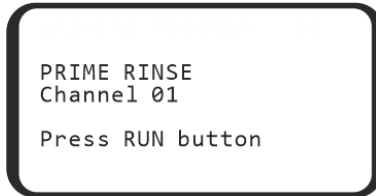

Figure 13. Rinsing the tubes, channel selection.

6.2.4 Press the ►/■ key and the system will perform the rinsing cycle. Repeat the procedure twice, if necessary.

6.2.5 Repeat steps 6.2.2–6.2.4 for the remaining tubes.

6.3 After finishing the operation, remove the tube from the valve opening (fig. 2/6) to prevent deformation (wall gluing) of the dosing valve tube. To remove the tube, press the valve on the side and stretch the tube a little when pulling it through the opening (fig. 2/↔).

6.4 Switch the unit off using mains switch on the rear panel (position **O**, off). Unplug the external power supply from the mains.



Caution! Before transporting the unit at low temperatures, disconnect the tubes from the buffer bottles and air-dry the tubes, following steps 6.2.2–6.2.4. It is not necessary to carry out this procedure every time you finish operation of the unit.

7. Specifications

7.1 Biosan is committed to continuous improvement of the unit's properties and quality and reserves the right to alter unit's design and specifications without additional notice.

7.2 Washing parameters

Dispense system of liquid dosage for each channel separately;

Minimum dispense volume	25 µl
Maximum dispense volume	1600 µl
Dispense increment	25 µl
Irregular liquid dosage at 300 µl	max. ±2.5% or 7.5 µl
Allowed residual liquid volume in plate well	max. 2 µl
Number of wells washed simultaneously	8
Number of washing cycles.....	1–15
Aspiration time	0.2–3 s
Aspiration/dispensing speed	3 levels
Choice of 3 washing buffers	
Maximum number of washing liquids in program	2
Dispense system	pinch valve
Soaking time	0–300 s (increment 10 s)
Shaking time.....	0–150 s (increment 5 s)
Number of washed rows	1 – 12
Time of plate single wash (350 µl)	max. 45 s

7.3 General parameters

Number of programs	101
Plate platform and manifold movement	automated
Indication of operation modes	8-line LCD
Dimensions	375x345x180 mm
Weight, accurate within ±10%	11 kg
Operating voltage	12 V=
Operating current	1.8 A
Power consumption	22 W
External power supply	input 100–240 V~, 50/60 Hz, output 12 V=

7.4 Workroom requirements.

Workroom description	Cold rooms and closed laboratory rooms
Temperature range	+4 °C ... +40 °C
Humidity requirements	Maximum of 80% RH at 31 °C, decreasing linearly to 50% RH at 40 °C. Non-condensing atmosphere.
Operating height, maximum	2000 m ASL
Overvoltage category	I
Pollution degree	2

8. Ordering information

8.1 Models and versions available:

Model	Version	Electrical specifications	Catalogue number
IW-8, Intelispeed Washer	V.6AW	230 V~, 50/60 Hz, EU plug (type E/F)	BS-060106-AAI
		230 V~, 50/60 Hz, UK plug (type G)	BS-060106-AAI
		230 V~, 50/60 Hz, AU plug (type I)	BS-060106-AAI
		100–120 V~, 50/60 Hz, US/JP plug (type B)	BS-060106-AAI

8.2 To inquire about or order the optional accessories or the replacement parts, contact Biosan or your local Biosan representative.

8.2.1 Optional accessories:

Description	Catalogue number
4CHW Logger, 4-channel washing solution weight logger, max. loading per scale cup 2 kg, dimensions 267x252x97 mm, weight 3 kg	BS-060102-AK

8.2.2 Replacement parts:

Description	Catalogue number
Bottle #1, assembled (with weight, tube, filter)	BS-060102-S26
Bottle #2, assembled (with weight, tube, filter)	BS-060102-S27
Bottle #3, assembled (with weight, tube, filter)	BS-060102-S28
Bottle #4, assembled with tube	BS-060102-S29
Bottle #5, assembled (with filter, tube)	BS-060102-S43
Hydrophobic filter for bottle #5	BS-060102-S44
Filter complete set: filter, weight, tube	BS-060102-S01
Silicone tube set, 6 pcs.	BS-060102-S39

9. Care and maintenance

9.1 Service.

- 9.1.1 If the unit is disabled (e.g., no aspiration, no reaction to key presses, etc.) or requires maintenance, consult the error message and troubleshooting tables below, in **9.1.5** and **9.1.6**. If the problem is not covered, disconnect the unit from the mains and contact Biosan or your local Biosan representative.
- 9.1.2 All maintenance and repair operations (except listed below) must be performed only by qualified and specially trained personnel.
- 9.1.3 Do not fit incorrect spare parts to the appliance. The manufacturer will provide all necessary services, spare parts and subassemblies. To order the required services and parts, contact your supplier.
- 9.1.4 Operating integrity check. If the unit follows the procedure described in sections **4.** to **6.**, then no additional checks are required.
- 9.1.5 **Error messages.** Table below shows the program cycle error messages, their description and possible solutions that can be made by user.



Caution! If the error message is not listed, copy the error text, unpower the unit and forward the error text to Biosan or your local Biosan representative.

Table 3. Program error messages

Displayed message	Description	Solution
CANCELED BY OPERATOR	Program execution is stopped by operator.	Press ►/■ key
BOTTLE 4 OVERFLOWED	Overflow of waste collection bottle.	Empty the bottle
BOTTLE ## EMPTY	Buffer bottle needs to be filled.	Fill the bottle
PLATE ERROR	Plate calibration is required.	See 5.5

- 9.1.6 **Troubleshooting.** Table 4 below lists some malfunctions that can be removed by the user.



Caution! If the problem persists or is not listed, unpower the unit and forward the error text to Biosan or your local Biosan representative.

Table 4. Troubleshooting table

Symptom	
Possible cause	Action required
<i>Manifold dosing error. Volume of washing solution does not correspond to the set volume; dosing unevenness is observed along the plate wells, or the washing solution is not dispensed at all.</i>	
1. Poor contact between the bottle hose connector and the device 2. The hose is overbent 3. Obstruction of sieve filters 4. Obstruction of dispensing channel of the manifold or a needle 5. Absence of liquid in bottles	1. Ensure proper connection of the bottle with the device. 2. Check if the hose is overbent and straighten it if necessary. 3. Check if the sieve filters in bottles No. 1, 2 and 3 are clogged. 4. Check if the dispensing channel of the manifold or needles is not obstructed. If yes, perform cleaning (see "Obstruction of dispensing channel or a needle in the manifold" in this Table). 5. Ensure presence of liquid in the bottles No. 1, 2 and 3; fill up liquid in a bottle if needed. (Attention: with 4CHW Logger, information on liquid levels in bottles is shown on the display).

Symptom	
Possible cause	Action required
During operation needles of the manifold can be obstructed.	<ol style="list-style-type: none"> 1. Determine the obstructed needle by checking the underfilling of a well. Warning! Be careful working with the manifold, prevent pricks and injuries caused by needles, they may contain dangerous infections! 2. Take off the manifold from the device, put it down with needles upward. Clean the aspiration channel needles with the wiping rod Ø 0.80 mm, and clean needles of the dispensing channel with the wiping rod Ø 0.45 mm, inserting the wiping rod against stop and removing it. 3. After cleaning, install the manifold on the device and do the rinsing procedure to ensure proper operation of the needle. 4. In case of repeated obstruction, execute requirements of pp. 1 and 2, unscrew the manifold's plugs, disconnect the dispensing and aspirating tubes, clean the dispensing or aspiration channel with the wiping rod, rinse the manifold with the 75% solution of ethanol, replace the plugs, install the manifold on the device and ensure the proper operation of needles.
<i>Washing solution is not dispensed into a plate</i>	
Deformation (wall gluing) of dosing valve tube due to the long-term storage or standstill of the device	<ol style="list-style-type: none"> 1. Remove the tube from the valve. 2. In the case of deformation, open with fingers the closed part of the dosing valve. 3. Insert the tube into the valve opening to position shown in fig. 2/6. Note: In order to release the tube, press the valve on the side and slightly stretch the tube pulling it through the opening.
<i>Aspiration is not effective in an unevenly filled row of wells</i>	
Manifold needles aspirate air from empty wells, reducing effectiveness	Run a program with aspiration only (see 5.6 , highest aspiration speed and time and no dispensing), multiple times, if necessary.
<i>Volume of residual liquid in a well exceeds the admissible value (2 µL)</i>	
<ol style="list-style-type: none"> 1. Depth of the manifold immersion is not determined. 2. Obstruction of the manifold aspiration channel or a needle. 	<ol style="list-style-type: none"> 1. Perform well depth measurement in the automatic mode, see 5.5. 2. Check if the aspiration channel and needles are not obstructed. If yes, do their cleaning (see "Obstruction of dispensing channel or a needle in the manifold" in this Table). 3. If it does not help, turn off the device and have it checked by a specialist.
<i>On starting the operation, the device does not fetch liquid from the active bottle.</i>	
Insufficient liquid quantity in the pipe.	<p>To solve this problem, complete the following procedure:</p> <ul style="list-style-type: none"> - Stop the program. - Prepare a syringe (included, fig. 1/15) with 5 ml of distilled water. - Unscrew the hose from the active bottle. - Press Prime Rinse key. - Using + and - keys, select number of the active bottle and press the ▶/■ key. - At the moment when the pump begins operation, gradually fill the hose with distilled water from the syringe. - Tighten the hose on the bottle. <p>If the pump does not restore performance, contact the service engineer</p>

9.2 Cleaning and disinfection.

9.2.1 Before starting the washing procedure, rinse the system with distilled water as described in section **Operation closedown**.

9.2.2 Use mild soap and water with a soft cloth or sponge for cleaning the exterior. Rinse remaining washing solution with distilled water. Wipe dry the excess water with clean, soft cloth or sponge, paying special attention to the guiding rail (fig. 2/5).

9.2.3 To disinfect the plastic and metal parts, especially plate platform and the flat spring in it, use 75% ethanol or DNA/RNA removing solution (e.g., Biosan PDS-250). After disinfecting, wipe the surfaces dry.

9.2.4 **Autoclaving.** Unit and its accessories are not autoclavable.

9.3 Filter replacement (figure 14).

9.3.1 Change the hydrophobic filter once every six months, in particular cases, e.g., after intensive operations, once every three months. To order the filter, look up the product's catalogue number, see **8.2.2**.

9.3.2 Disconnect the filter from outlet tube, remove the filter, insert a new filter into the socket and tighten it.



Caution! Maintain the mounting of the filter according to figure 14. The **IN** marking should be located on the side of the inlet tube (facing the bottle).

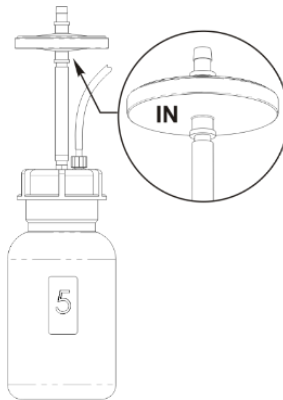

Figure 14. Filter mount

9.4 **Disposal.** Disposal of the appliance requires special precautions and must be carried out at an appropriate disposal site, separate from normal household waste. To prevent pollution of the environment, all waste resulting from the disposal of the product must be collected and disposed of in the country of use, in accordance with the applicable requirements for the handling of electronic waste.

10. Storage and transportation

- 10.1 Store and transport the unit in a horizontal position (see package label) at ambient temperatures between -20°C and +60°C and maximum relative humidity of 80%.
- 10.2 After transportation or storage and before connecting it to the electric circuit, keep the unit under room temperature for 2-3 hrs.
- 10.3 **Extended storage.** For long-term storage, keep the appliance and its accessories in their original packaging, in a dry, dust-free place. For transportation, always pack the appliance in its original packaging, regardless of whether it is to be transported by land, water or air. To pack the appliance correctly, proceed as follows:



Caution! Before transporting the unit at low temperatures, disconnect the tubes from the buffer bottles and air-dry the tubes, following steps **6.2.2–6.2.4**. It is not necessary to carry out this procedure every time you finish operation of the unit.



Caution! We do not accept warranty claims related to damages caused by improper packaging.

- 10.3.1 Remove the manifold, tubes and platform for plates.
- 10.3.2 Cover unit sides with cut-out covers and place it into the original carton box.
- 10.3.3 Place the manifold into protecting case; place syringe, manifold cleaning set and the platform into PE bag. Place the bag and the case with the manifold in the corners of the box between the packaging blocks and the side panels of the carton box; place the 2-litre bottle and the half-litre bottle in free space between the packaging blocks and the side panels of the carton box.
- 10.3.4 Insert the top section into the carton box by bending the section downwards along the perimeter and inserting the bent parts between the walls of the original carton box and packaging blocks, so that the device and the remaining content of the box are fully covered.
- 10.3.5 Put the soft foam sheet (grey) with the smooth side down on the resulting horizontal carton surface.
- 10.3.6 Put the remaining three bottles and other accessories on the foam sheet.
-  **Note.** If 4-channel weight logger is included in the kit, insert pads under scale cups, then place the logger into top section of packaging.
- 10.3.7 Cover everything with another sheet of soft foam material with the smooth side up.
- 10.3.8 Close the box and seal with packing tape.

11. Warranty

- 11.1 The Manufacturer guarantees the compliance of the unit with the requirements of Specifications, provided the Customer follows the operation, storage and transportation instructions.
- 11.2 The warranted service life of the unit from the date of its delivery to the Customer is 24 months, excluding optional accessories mentioned in the section **Ordering information**. For extended warranty, see **11.5**.
- 11.3 Warranty covers only the units transported in the original package.
- 11.4 If any manufacturing defects are discovered by the Customer, an unsatisfactory equipment report shall be compiled, certified and sent to the local distributor address. To obtain the claim form, visit **Technical support** page on our website at link below.
- 11.5 Extended warranty. For **IW-8**, the *Premium* class model, one year of extended warranty is available free of charge after registration, during 6 months from the date of sale. Online registration form can be found in section **Warranty registration** on our website at the link below.
- 11.6 Description of the classes of our products is available in the **Product class description** section on our website at the link below.

Technical support



biosan.lv/en/support

Registration



biosan.lv/register-en

Product class description



biosan.lv/classes-en

- 11.7 The following information will be required in the event that warranty or post-warranty service comes necessary. Complete the table below and retain for your record.

Model	Serial number	Date of sale
IW-8, Intelispeed washer		

- 11.8 **Production date.** Production date is placed in the serial number, on the label of the unit. Serial number consists of 14 digits styled XXXXXYYMMZZZZ, where XXXXXX is model code, YY and MM – year and month of production, ZZZZ – unit number.

12. EU declaration of conformity

12.1 Intelispeed washer **IW-8** is in conformity with the following relevant Union legislations:

LVD 2014/35/EU	LVS EN 61010-1:2011 Safety requirements for electrical equipment for measurement, control, and laboratory use. General requirements.
EMC 2014/30/EU	LVS EN 61326-1:2013 Electrical equipment for measurement, control and laboratory use. EMC requirements. General requirements.
RoHS3 2015/863/EU	Directive on the restriction of the use of certain hazardous substances in electrical and electronic equipment.
WEEE 2012/19/EU	Directive on waste electrical and electronic equipment.

12.2 Declaration of Conformity is available for download on the page for the relevant model on our website by links below, in the **Downloads** section:



[Intelispeed washer IW-8](#)

This page intentionally left blank

This page intentionally left blank

SIA Biosan

Ratsupites 7 k-2, Riga, LV-1067, Latvia

Phone: +371 67426137 Fax: +371 67428101

<https://biosan.lv>

Edition 6.01 – December of 2023