



Find out about our special offer
on <https://biosan.lv/classes-en>



Inteliwasher 3D-IW8 Microplate Washer



User instructions

If you have any feedback on our products or services, we would like to hear from you.
Please send all feedback to:

Manufacturer:

SIA Biosan
Ratsupites 7 k-2, Riga, LV-1067, Latvia

Phone: +371 674 261 37

Fax: +371 674 281 01

<https://biosan.lv>

Marketing: marketing@biosan.lv

Service: service@biosan.lv

Contents

1.	About this edition of user instructions.....	3
2.	Safety precautions	4
3.	General information.....	6
4.	Getting started.....	8
5.	Operation	12
6.	Operation shutdown	17
7.	Specifications	18
8.	Ordering information	19
9.	Care and maintenance	20
10.	Storage and transportation.....	23
11.	Warranty.....	24
12.	EU declaration of conformity	25

1. About this edition of user instructions

1.1 The current edition of the user instructions applies to the following models:

Model and name	Version
FTA-1, aspirator with trap flask	V.4AW

1.2 Edition 3.03 – August of 2022.

2. Safety precautions



Caution! Please make sure you have fully read and understood current instructions before using the equipment and pay special attention to sections marked by this symbol.

2.1 Icons used on the unit and packaging

	CE marking, manufacturer affirms conformity with European health, safety, and environmental protection standards, see 12.1
	WEEE directive marking, see 12.1
	Polarity of the power connector
	Equipment uses direct current
	Warning: Always perform the rinsing cycle using distilled water and dry the system after operation. This will keep the unit in working order and prevent channel clogging.

2.2 General safety precautions

- The protection provided can be ineffective if the operation of the appliance does not comply with the manufacturer's requirements.
- Save the unit from shocks and falling.
- Store and transport the unit as described in section **10. Storage and transportation**.
- Use only original parts and accessories, provided by manufacturer for this product.
- Before using any cleaning or decontamination methods except those recommended by the manufacturer, check with the manufacturer that the proposed method will not damage the equipment.
- Do not make modifications in design of the unit.

2.3 Electrical safety

- Connect only to an external power supply with voltage corresponding to that on the serial number label.
- Use only the external power supply provided with this product.
- Do not plug the power supply into an ungrounded power socket, and do not use an ungrounded extension lead.
- Ensure that the switch and external power supply connector are easily accessible during use.
- Disconnect the unit from the mains before relocating it.
- If liquid penetrates into the unit, disconnect it from the mains and do not use it until it is checked by a repair and maintenance technician.
- Do not operate the unit in premises where condensation can form. Operating conditions of the unit are defined in section **7. Specifications**.

2.4 During operation

- Do not operate the unit in environments with aggressive or explosive chemical mixtures. Please contact manufacturer for possible operation of the unit in specific atmospheres.
- Before changing the manifold, the bottles or the tubes, disconnect the unit from the mains.
- Do not operate the unit if it is faulty.
- Always have the cover protecting against aerosol spread (hereinafter protective cover) installed during operation.
- Do not operate the unit without the manifold installed.
- Do not operate the unit if any of the needles is clogged or malfunctions.
- Never touch the needles or place fingers or other parts under the needles during operation. Manifold needles are sharp and can cause injury.
- If liquid spills on the guiding rail, stop the operation, clean and wipe the surface dry.
- Do not allow the waste bottle to overflow the maximum level during operation (there is a mark on the side surface of the bottle). Take necessary precautions utilizing waste liquid in accordance with general laboratory standards.

2.5 After operation

- Carry out the cycle of system washing as described in section **6. Operation closedown**. This will keep the system in permanent operation condition.
- Clean the guiding rail under the platform and wipe it dry to prevent oxidation layer formation and to prolong working life of the unit.

2.6 Biological safety

- It is the user's responsibility to carry out appropriate decontamination if hazardous material is spilt on or penetrates into the equipment.
- In diagnostic research, potentially dangerous biological materials can be used. When working with such materials, always use protective clothing and eye protection. Always have the protective cover installed during operation.

3. General information

Inteliwasher 3D-IW8 series microplate washer is designed for washing various types of standard microplates, microstrips and microarrays on FastFRAME (rectangular well shape frame). Washer is suitable for washing wells with different bottom shapes, flat, U-shape and V-shape. The unit is fully programmable, ensuring multi-step solution ripening, aspiration and soaking cycle during a particular period of time, as well as combinations of aspiration, liquid dispensing and soaking.

The unit has 50 programs divided into 5 following aspiration categories (Scheme 1):

- **Type 1** (programs 1.0–1.9) IPF96 U/V is intended for U-shape and V-shape immunoplates, 1 point aspiration.
- **Type 2** (2.0–2.9) IPF96 FLAT-2 is intended for flat-bottom shape immunoplates, 2-point aspiration.
- **Type 3** (3.0–3.9) IPF96 FLAT-C is intended for rectangular shape immunoplates, full-circle aspiration direction.
- **Type 4** (4.0–4.9) FastFRAME-2 is intended for multi-slide¹ plate with rectangular wells.
- **Type 5** (5.0–5.9) FastFRAME-C is intended for multi-slide¹ plate with rectangular wells.

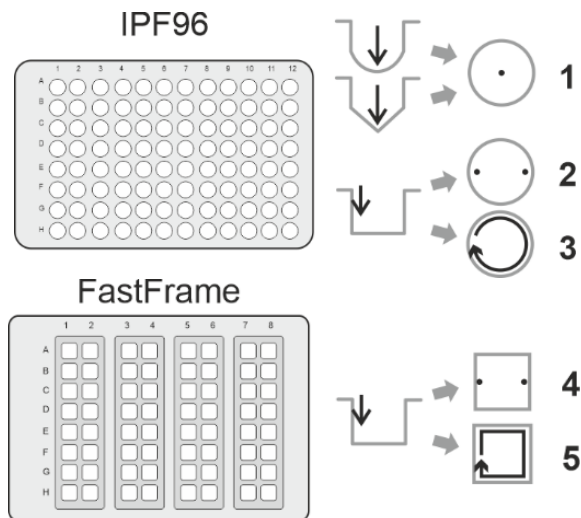

Figure 1. Aspiration methods

¹ The FastFRAME (Schleicher&Shuell) multi-slide plate or analog plate of another manufacturer, that is compatible with standard 1 x 3 inch (25 x 76 mm) glass slides.

Optional 4-channel washing solution weight logger, **4CHW Logger** allows automatic buffer bottles and waste bottle volume control.

The unit is supplied with 8-channel washing head for dispensing/aspiration, 3 bottles for washing and rinsing solutions, a large waste bottle and small aerosol catching bottle with hydrophobic filter that eliminates risk of contamination with bacteria, viruses and infected particle from wasted liquid to an atmosphere. Hydrophobic filter bacterial efficiencies are exceedingly high, up to 99.999% particles bigger than 0.027 μm (which is smaller than Hepatitis A, B and C).

The unit provides:

- washing mode;
- rinsing mode;
- mixing mode;
- single point, two point, circular (circle or rectangular path);
- possibility of additional solution mixing during time gap between two work cycles;
- possibility to use microtest plates by different manufacturers, ensured by automated plate set up (adjusting to different depths of plate wells);
- round-bottom plate and strip washing mode;
- possibility of user-defined programs with adjustable parameters.

4. Getting started

4.1 **Unpacking.** Remove packing materials carefully and retain them for future shipment or storage of the unit. Examine the unit carefully for any damage incurred during transit. The warranty does not cover in-transit damage. Warranty covers only the units transported in the original package.

4.2 **Complete set.** The set includes:

	Name	Quantity
1	Inteliwasher 3D-IW8, microplate washer	1 pce.
2	Platform for plates	1 pce.
3	Manifold	1 pce.
4	Protecting cover	1 pce.
5	External power supply	1 pce.
6	Tubes (outside/inside diam./length 6/3/600 mm)	5 pcs.
7	Tube for manifold (outside/inside diam./length 3.2/1.6/400 mm)	1 pce.
8	Tube for manifold (outside/inside diam./length 5/3/440 mm)	1 pce.
9	Tube for hydrophobic filter (outside/inside diam. 9/6 mm)	1 pce.
10	Half-litre bottle with connectors for aerosol collection	1 pce.
11	1-litre bottles with sieve filters and connectors for reagents	3 pcs.
12	2-litre bottle with connector for collecting of waste liquid	1 pce.
13	Hydrophobic filters for half-litre bottle	2 pcs.
14	Manifold cleaning set	1 pce.
15	Syringe for liquid flushing in hoses	1 pce.
16	Power cord	1 pce.
17	User instructions, declaration of conformity	1 copy
18	4-channel washing solution weight logger, 4CHW Logger (<i>on request</i>)	1 set

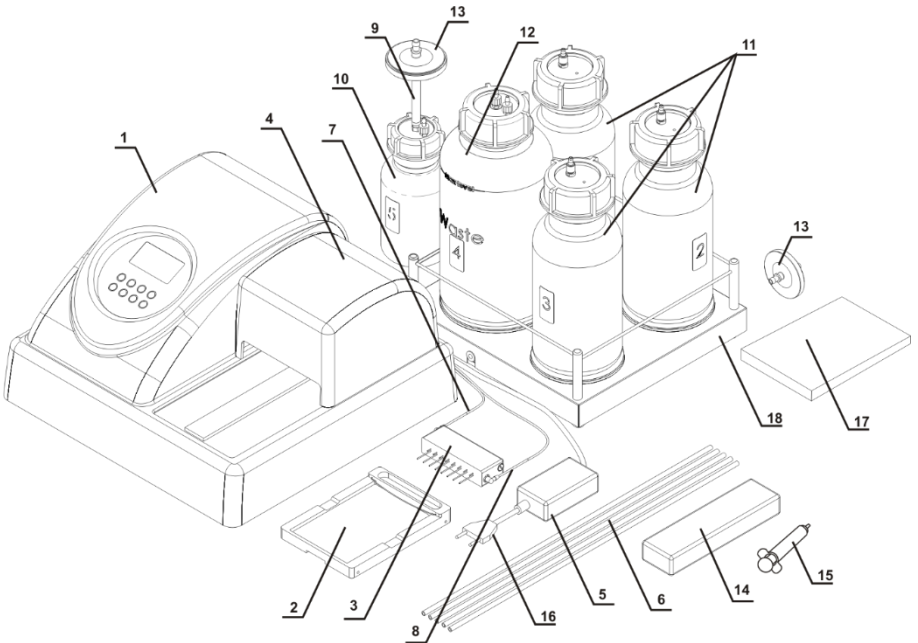

Figure 2. Complete set

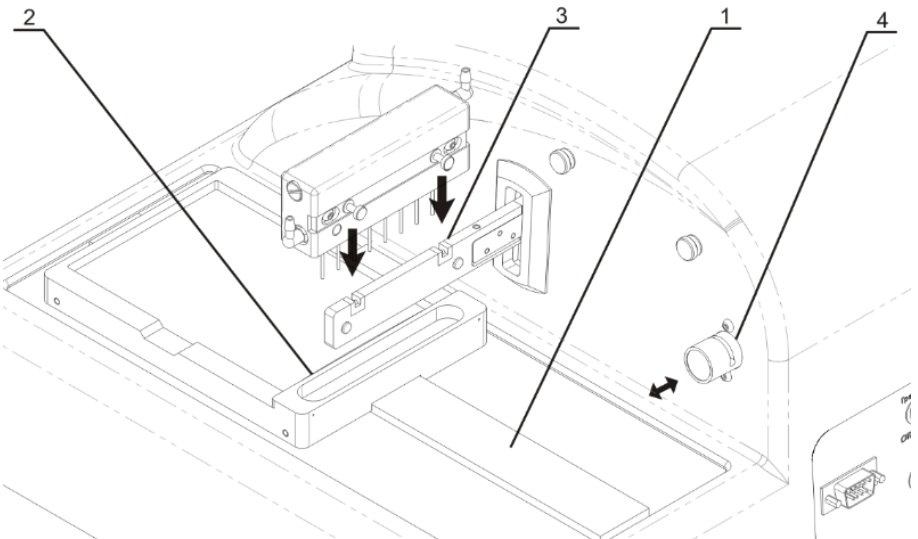

Figure 3. Unit side and back overview. Setting up.

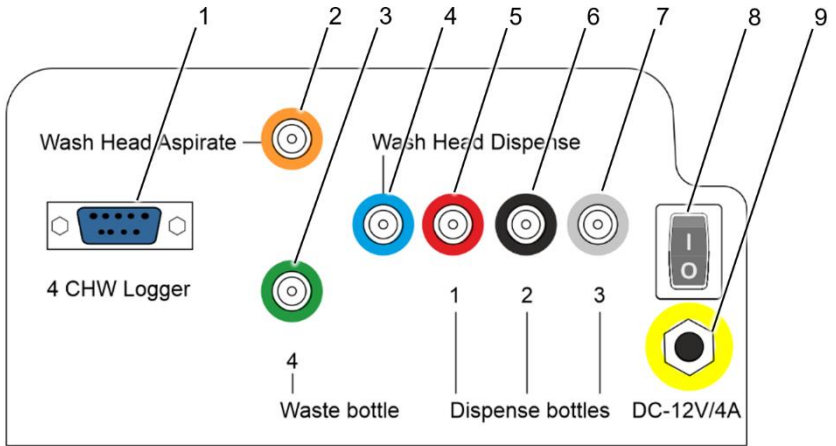

Figure 4. Rear panel

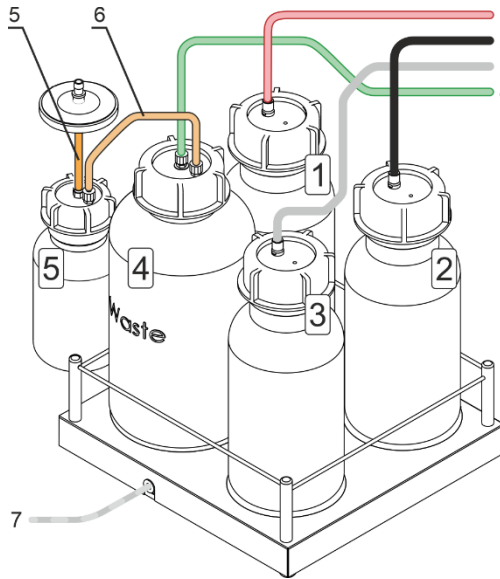

Figure 5. Bottles and tubing

4.3 Setup.

4.3.1 Place the unit on a strong horizontal surface, which can safely support weight of the unit. To provide optimal ventilation, ensure 100 mm clearance on each side. Operation conditions are described in the **Specification** section.

4.3.2 Remove the protecting cover.

4.3.3 Unpack the plate platform (fig. 2/2).

4.3.4 Place the plate platform on the railing (fig. 3/1) so that the plate holder (flat spring) faces the rear side of the unit (fig. 3/2). Magnet on the other side of the rail locks the platform into start position.



Note. If the plate platform is installed improperly, the magnet does not hold it in place and the platform will be able to move freely. Move the platform along the railing until the magnets lock. Increase of resistance to movement indicates that the magnets are locked.

4.3.5 Unpack the manifold.

4.3.6 Install the manifold in the slots of the holder arm (fig. 3/3). Magnets in the manifold and the holder arm connect and align the manifold.

4.3.7 Connect the unit parts with the tubes as described below:



Note. Each tube (fig. 2/6–2/8) and manifold (fig. 4/2–4/7) are colour-coded. Ensure that the tubes are connected securely.

Tube	Connectable parts	
Thin tube with a yellow strip (fig. 2/7)	Wash head dispenser manifold, higher and closer to display (fig. 3)	Yellow manifold Wash Head Dispense on the rear panel (fig. 4/4)
Thin tube with a blue strip (fig. 2/8)	Wash head aspiration, lower and farther from display (fig. 3)	Blue manifold Wash Head Aspirate on the rear panel (fig. 4/2)
Tube with a green strip (fig. 5/4)	Central manifold on the 2L bottle #4 (fig. 5)	Green manifold 4 Waste bottle on the rear panel (fig. 4/3)
Tube w/o strip (fig. 5/6)	Side manifold on the 2L bottle #4 (fig. 5)	Side manifold on the 0.5L bottle #5 (fig. 5)
Short wide tube (fig. 5/5)	Central manifold on the 0.5L bottle #5 (fig. 5)	Aspiration filter (fig. 2/13), side with the marking IN
Tube with a red strip (fig. 5/1)	Manifold on the 1L bottle #1 (fig. 5)	Red manifold 1 Dispense bottles on the rear panel (fig. 4/5)
Tube with a black strip (fig. 5/2)	Manifold on the 1L bottle #2 (fig. 5)	Black manifold 2 Dispense bottles on the rear panel (fig. 4/6)
Tube with a white strip (fig. 5/3)	Manifold on the 1L bottle #3 (fig. 5)	White manifold 3 Dispense bottles on the rear panel (fig. 4/7)
4 CHW Logger adapter cable (fig. 5/7, if in use)	4 CHW Logger connector on the rear panel (fig. 4/1)	

4.3.8 Insert the manifold tube (fig. 3/2) into the valve opening (fig. 3/4). Press the valve in the direction of the arrow and hold the valve while stretching the tube and pulling it through the opening. Release the valve.

4.3.9 Install the protective cover. Ensure that all tubes are covered but are not squeezed.

4.3.10 Place the bottles near the unit. If **4 CHW Logger** is in use, remove pads from underside of scale cups and place the bottles accordingly.

5. Operation

5.1 This section describes the following actions:

- Switching on and preparing the unit for operations.
- Microplate setup and unit calibration.
- Program choice and setup.
- Starting the chosen program.

5.2 **Switching on.**



Caution! Before connecting the unit to the mains outlet, check that the power switch (fig. 4/9) is in position **O** (off).

- Connect the external power supply to the power socket (fig. 4/8) on the rear panel of the unit.
- Connect the power cord to the external power supply (fig. 2/16)
- Connect the external power supply to the grounded power socket.
- Position the unit with easy access to the plug and the power switch.
- Switch on the unit (position **I**) using the power switch (fig. 4/8) on the rear panel.
- When switched on, the unit performs full initialisation cycle and displays the message "Power on reset" (figure 6)



Note. Full initialisation cycle takes no longer than 5 seconds.

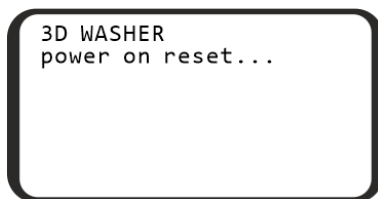

Figure 6. Initialisation screen

5.3 Before starting plate washing:

- Fill the rinsing liquid bottle #3 with distilled water or an appropriate cleansing solution.
- Fill the necessary bottles #1 and/or #2 with washing solutions.

5.4 Microplate installation. Hold the plate platform in place with one hand and place the microplate on the plate platform on the other by pressing the flat spring on one side of the platform.



Caution! When installing a type of plate for the first time, perform the plate setup to adjust the manifold lowering depth (see paragraph 4.20).



Note. When working with the FastFRAME plates, remove the plate holder (fig. 3/2). Install it back after operations.

5.5 **Program selection.** All programs are divided into 5 categories with 10 programs each. Each category corresponds to a different type of microplate and therefore, to a different aspiration method (see figure 1):

- Category **IPF96 U/V** (1) is intended for U-shape and V shape well immunoplates.
- Categories **IPF96 FLAT-2** (2) and **IPF96 FLAT-C** (3) are intended for flat-bottom well immunoplates.
- Categories **FastFRAME-2** (4) and **FastFRAME-C** (5) are intended for Watman Schleicher & Shuell FastFRAME plates with rectangular wells.

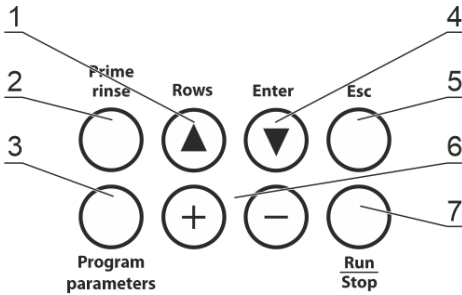

Figure 7. Control panel keys

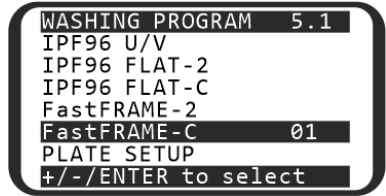

Figure 8. Program selection

5.5.1 To navigate the menu:

- To select a row, press the **Enter ▼** key (fig. 7/4). Row selection is looped.
- To change the row value, use the **+** and **-** keys (fig. 7/6)

5.5.2 In figure 8, the user chose the first program (01) of the fifth type (FastFRAME). The choice can be seen in the top right corner (5.1).

5.6 **Changing the parameters of a program.**

5.6.1 The manufacturer has pre-set parameters in each of the ten programs in each category. Any parameter can be changed before selecting a program. Table 1 shows the default program parameters. Table 2 shows the adjustable ranges and a description of each parameter.

Table 1. Initial parameters of all user programs.

Parameter	Program number in the category									
	1	2	3	4	5	6	7	8	9	0
Dispense	YES	YES	YES	YES	YES	YES	YES	YES	YES	YES
Aspirate	YES	YES	YES	YES	YES	YES	YES	YES	YES	YES
Shake	NO	NO	NO	NO	NO	NO	NO	NO	NO	NO
Dispense rate	03	03	03	03	03	03	03	03	03	03
Aspirate rate	03	03	03	03	03	03	03	03	03	03
Soak time, s	-	30	30	30	30	30	30	30	30	30
Shaking time, s	-	-	-	-	-	-	-	-	-	-
Dispensed volume	-	350	350	350	350	350	350	350	350	350
Aspirat. time, s	1	1	1	1	1	1	1	1	1	1
Final aspirat., s	-	2	2	2	2	2	2	2	2	2
First aspirate	-	NO	YES	YES	NO	YES	YES	YES	YES	NO
Wash by rows	-	NO	YES	YES	NO	YES	YES	YES	YES	NO
On two channels	-	NO	NO	YES	NO	YES	YES	NO	NO	NO
Num.of wash cycles	1	1	5	5	1	3	5	7	7	5
The channel	1	1	1	1	1	1	1	1	1	1
Second chan. cycles	-	-	-	1	-	1	1	-	-	-
Second channel	-	-	-	2	-	2	2	-	-	-

Table 2. Program parameters and their definitions

Parameter	Value or range	Description
Dispense	yes/no	Perform fill
Aspirate	yes/no	Perform aspiration ¹
Shake	yes/no	Plate shaking on the platform during the cycle
Dispensing rate	01..03	Speed of liquid filling (100; 200; 300 µL/s)
Aspirating rate	01..03	Speed of liquid aspiration (100; 200; 300 µL/s)
Soak limit, s	0..300	Time between fill and aspiration (step 10 s)
Shaking time, s	05..150	Shaking time (step 5 s)
Dispensed volume	25..1600	Volume of dispensed liquid (step 25 µL)
Aspirat. time, s	200..3000 ms	Time of aspiration from well in cycle (step 200 ms)
Final aspirat., s	200..3000 ms	Time of last aspiration in the cycle (step 200 ms)
First aspirate	yes/no	Aspiration is the first action in a cycle
Wash by rows	yes/no	Each row is washed once per cycle
On two channels	yes/no	Use 2 washing solutions
Num. of wash. cycles	01..15	Number of washes with first solution
The channel	01..03	Number of bottle to use for the main washing
Second chan. cycles	01..15	Number of washes with second solution
Second channel	01..03	Number of bottle to use for the second washing

¹ During aspiration, the waste fluid bottle is detected automatically – bottle #4. The number is not specified on the display



Note. If some of the parameters from Tables 1 and 2 are set to NO, the associated items will not appear in the parameter change menu. For example, Second chan. cycles and Second channel only appear if On two channels is set to YES.

5.6.2 To view the parameters of a program, press the **Program Parameters** key (fig. 7/3).

5.6.3 To navigate the parameters menu (figure 9):

- To select a row, use **Rows ▲** and **Enter ▼** keys.
- To change the value of a selected row, use **+** and **-** keys.
- To exit the parameter changing mode and save the changes, press the **Program parameters** key again.
- To exit without saving, press the **Esc** key (fig. 7/5)

5.7 Running the program.

5.7.1 By default, the unit washes all rows of the microplate. In order to wash less rows, when in the program selection menu (figure 8) press **Rows ▲** (fig. 7/1). Display shows the row count menu (figure 10). Using the **+** and **-** keys, set the necessary number of rows. To cancel and return to the previous menu, press **Esc**. To save and start the program, continue reading.

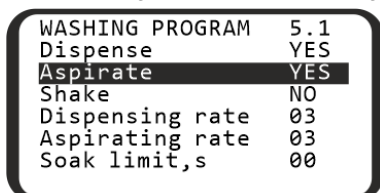

Figure 9. Program parameters

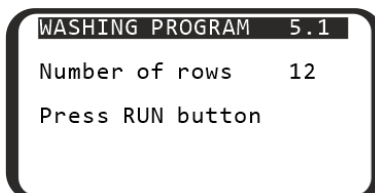

Figure 10. Row count selection menu

5.7.2 Press the **Run/Stop** key (fig. 7/7) to start the program. The program can be started from the program selection menu, program parameters menu, or row count selection menu (figures 8, 9, or 10). To abort and return to program selection, press **Esc** key.

5.7.3 If the operation requires washing on two channels (parameter **On two channels** set to **YES**), then after starting the program, unit requests the confirmation of the correct bottle number for second wash. (figure 11) Select the necessary bottle number using **+** and **-** keys and press the **Run/Stop** key.

5.8 During operation.

5.8.1 During operation, display (figure 12) shows the program number (**5.1**), number of the bottle in use (**1**), the current cycle (**03**) and the current timed action (**Shake .. 05**).

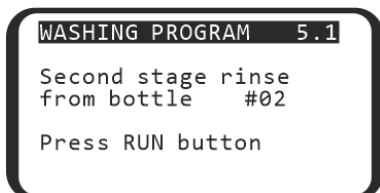

Figure 11. Second bottle confirmation



Figure 12. Running program

5.8.2 If **4 CHW Logger**, the 4-channel washing solution weight logger is connected to the unit, then in addition to values on figure 12, display shows percentage of the remaining volume of liquid in the bottles (figure 13). For the waste bottle #4, percentage values will be increasing.

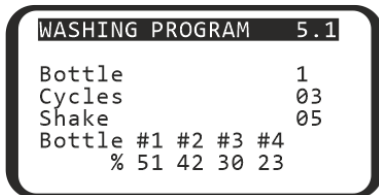

Figure 13. Running program with 4CHW Logger attached

5.9 To stop the program during operation, press the **Run/Stop** key. The message **CANCELLED BY OPERATOR** appears on the lower line of the display. Press the **Run/Stop** key to restart the operation.

5.10 When the cycle is completed, unit produces an informative sound signal. Proceed to the section **6. Operation closedown**.



Note. If in doubt as to whether the rinsing is complete and even, repeat the rinsing.

The quality of the plate washing affects the validity of the results obtained from the test. To ensure that the washing procedure was performed correctly, make periodic visual checks of the reproducibility of the dispensed volumes.

5.11 **Plate setup.** When installing a plate for the first time or when a plate of different type is used, setup the lowering depth of the manifold's needles.

- Press the **Enter ▼** key in the start mode, then the **Run/Stop** key, and the following message appears on the display (figure 14).
- To calibrate, press the **Run/Stop** key. The manifold measures the depth of the plate well by touching the plate surface first and then the bottom of the well. The unit saves the difference of the measured values.

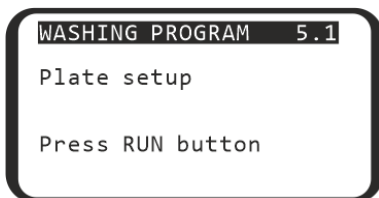

Figure 14. Plate setup

6. Operation shutdown

6.1 This section describes the required water rinsing procedures before shutdown.

6.2 Rinsing the tubes.



Caution! Always perform the rinsing cycle using distilled water after finishing the operation at the end of working day. This will help to keep the unit in working order and prevent tube clogging.

6.2.1 Fill one of the bottles ##1–3 with distilled water.

6.2.2 Attach the rinsible tube to this bottle.

6.2.3 Press the **Prime rinse** (fig. 7/2), display shows the rinsing menu (figure 15). Select the channel of the attached tube using the + and – keys. Channel number can be found on the rear panel of the unit, under the attached tube (fig. 4/5–4/7)

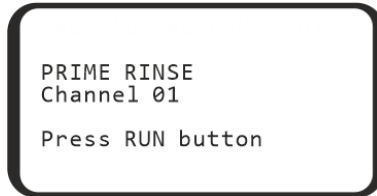

Figure 15. Rinsing the tubes, channel selection.

6.2.4 Press the **Run/Stop** key and the system will perform the rinsing cycle. Repeat the procedure twice, if necessary.

6.2.5 Repeat steps **6.2.2–6.2.4** for the remaining tubes.

6.3 After finishing the operation, remove the tube from the valve opening (fig. 3/4) to prevent deformation (wall gluing) of the dosing valve tube. To remove the tube, press the valve on the side and stretch the tube a little when pulling it through the opening (fig. 3/↔).

6.4 Switch the unit off using mains switch on the rear panel (position **O**, off). Unplug the external power supply from the mains.



Caution! Before transporting the unit at low temperatures, disconnect the tubes from the buffer bottles and air-dry the tubes, following steps **6.2.2–6.2.4**. It is not necessary to carry out this procedure every time you finish operation of the unit.

7. Specifications

The unit is designed for operation in cold rooms and closed laboratory rooms at ambient temperature from +4°C to +40°C in a non-condensing atmosphere and maximum relative humidity 80% for temperatures up to 31°C decreasing linearly to 50% relative humidity at 40°C. Operating altitude above sea level is up to 2000 m.

Biosan is committed to a continuous programme of improvement and reserves the right to alter design and specifications of the equipment without additional notice.

7.1	Dispense system of liquid dosage for each channel separately;	
7.1.1	Minimum dispense volume	25 µl
7.1.2	Maximum dispense volume	1600 µl
7.2	Dispense increment	25 µl
7.3	Irregular liquid dosage at 300 µl	max. ±2.5% or 7.5 µl
7.4	Allowed residual liquid volume in plate well	max. 2 µl
7.5	Number of wells washed simultaneously	8
7.6	Number of washing cycles	1–15
7.7	Aspiration time	1–3 s
7.8	Aspiration/dispensing speed	3 levels
7.9	Washing buffers	3 maximum
7.10	Maximum number of washing liquids in program	2
7.11	Dispense system	pinch valve
7.12	Soaking time	0 – 300 s (increment 10 s)
7.13	Shaking time	0 – 150 s (increment 5 s)
7.14	Number of washed rows	1–12
7.15	Time of plate single wash (350 µl)	max. 45 s
7.16	Number of programs	50
7.17	Plate platform and manifold movement	automated
7.18	Indication of operation modes	8-line LCD
7.19	Dimensions	375x345x180 mm
7.20	Weight, accurate within ±10%	11 kg
7.21	Operating voltage and current	12 V=, 1.8 A
7.22	Power consumption.....	22 W
7.23	External power supply	input 100–240 V~, 50/60 Hz, output 12 V=

8. Ordering information

8.1 Models and versions available:

Model	Version	Catalogue number
Inteliwasher 3D-IW8, microplate washer	V.3AW	BS-010212-AAA

8.2 To inquire about or order the optional accessories or the replacement parts, contact Biosan or your local Biosan representative.

8.2.1 Optional accessories

Description	Catalogue number
4CHW Logger, 4-channel washing solution weight logger, max. loading per scale cup 2 kg, dimensions 267x252x97 mm, weight 3 kg (accurate within $\pm 10\%$)	BS-060102-AAI

8.2.2 Replacement parts

Description	Catalogue number
Bottle #1, assembled (with weight, tube, filter)	BS-060102-S26
Bottle #2, assembled (with weight, tube, filter)	BS-060102-S27
Bottle #3, assembled (with weight, tube, filter)	BS-060102-S28
Bottle #4, assembled with tube	BS-060102-S29
Bottle #5, assembled (with filter, tube)	BS-060102-S43
Hydrophobic filter for bottle #5	BS-060102-S44
Filter complete set (filter, weight, tube)	BS-060102-S01
Silicone tube set, 6 pcs.	BS-060102-S39

9. Care and maintenance

9.1 Service.

- 9.1.1 If the unit is disabled (e.g., no aspiration, no reaction to key presses, etc.) or requires maintenance, consult the error message and troubleshooting tables below, in **9.1.5** and **9.1.6**. If the problem is not covered, disconnect the unit from the mains and contact Biosan or your local Biosan representative.
- 9.1.2 All maintenance and repair operations (except listed below) must be performed only by qualified and specially trained personnel.
- 9.1.3 Do not fit incorrect spare parts to the appliance. The manufacturer will provide all necessary services, spare parts and subassemblies. To order the required services and parts, contact your supplier.
- 9.1.4 Operating integrity check. If the unit follows the procedure described in sections **4.** to **6.**, then no additional checks are required.
- 9.1.5 **Error messages.** Table below shows the program cycle error messages, their description and possible solutions that can be made by user.



Caution! If the error message is not listed, copy the error text, unpower the unit and forward the error text to Biosan or your local Biosan representative.

Table 3. Program error messages

Displayed message	Description	Solution
CANCELED BY OPERATOR	Program execution is stopped by operator.	Press Run/Stop key
BOTTLE 4 OVERFLOWED	Overflow of waste collection bottle.	Empty the bottle
BOTTLE ## EMPTY	Buffer bottle needs to be filled.	Fill the bottle
PLATE ERROR	Plate calibration is required.	See 5.11

- 9.1.6 **Troubleshooting.** Table 4 below lists some malfunctions that can be removed by the user.



Caution! If the problem persists or is not listed, unpower the unit and forward the error text to Biosan or your local Biosan representative.

Table 4. Troubleshooting table

Symptom	
Possible cause	Action required
<i>Manifold dosing error. Volume of washing solution does not correspond to the set volume; dosing unevenness is observed along the plate wells, or the washing solution is not dispensed at all.</i>	
1. Poor contact between the bottle hose connector and the device 2. The hose is overbent 3. Obstruction of sieve filters 4. Obstruction of dispensing channel of the manifold or a needle 5. Absence of liquid in bottles	1. Ensure proper connection of the bottle with the device. 2. Check if the hose is overbent and straighten it if necessary. 3. Check if the sieve filters in bottles No. 1, 2 and 3 are clogged. 4. Check if the dispensing channel of the manifold or needles is not obstructed. If yes, perform cleaning (see "Obstruction of dispensing channel or a needle in the manifold" in this Table). 5. Ensure presence of liquid in the bottles No. 1, 2 and 3; fill up liquid in a bottle if needed. (Attention: with 4CHW Logger, information on liquid levels in bottles is shown on the display).

Table 4. Troubleshooting table (cont.)

Symptom	
Possible cause	Action required
<i>Obstruction of dispensing channel or a needle in the manifold</i>	
During operation needles of the manifold can be obstructed.	<ol style="list-style-type: none"> 1. Determine the obstructed needle by checking the underfilling of a well. Warning! Be careful working with the manifold, prevent pricks and injuries caused by needles, they may contain dangerous infections! 2. Take off the manifold from the device, put it down with needles upward. Clean the aspiration channel needles with the wiping rod Ø 0.80 mm, and clean needles of the dispensing channel with the wiping rod Ø 0.45 mm, inserting the wiping rod against stop and removing it. 3. After cleaning, install the manifold on the device and do the rinsing procedure to ensure proper operation of the needle. 4. In case of repeated obstruction, execute requirements of pp. 1 and 2, unscrew the manifold's plugs, disconnect the dispensing and aspirating tubes, clean the dispensing or aspiration channel with the wiping rod, rinse the manifold with the 75% solution of ethanol, replace the plugs, install the manifold on the device and ensure the proper operation of needles.
<i>Washing solution is not dispensed into a plate</i>	
Deformation (wall gluing) of dosing valve tube due to the long-term storage or standstill of the device	<ol style="list-style-type: none"> 1. Remove the tube from the valve. 2. In the case of deformation, open with fingers the closed part of the dosing valve. 3. Insert the tube into the valve opening to position shown in fig. 3/4. Note: In order to release the tube, press the valve on the side and slightly stretch the tube pulling it through the opening.
<i>Volume of residual liquid in a well exceeds the admissible value (2 µL)</i>	
<ol style="list-style-type: none"> 1. Depth of the manifold immersion is not determined. 2. Obstruction of the manifold aspiration channel or a needle. 	<ol style="list-style-type: none"> 1. Perform well depth measurement in the automatic mode, see 5.11. 2. Check if the aspiration channel and needles are not obstructed. If yes, do their cleaning (see "Obstruction of dispensing channel or a needle in the manifold" in this Table). 3. If it does not help, turn off the device and have it checked by a specialist.
<i>On starting the operation, the device does not fetch liquid from the active bottle.</i>	
Insufficient liquid quantity in the pipe.	<p>To solve this problem, complete the following procedure:</p> <ul style="list-style-type: none"> - Stop the program. - Prepare a syringe with 5 ml of distilled water. - Unscrew the hose from the active bottle. - Press Prime Rinse key. - Using + and - keys, select number of the active bottle and press the Run/Stop key. - At the moment when the pump begins operation, gradually fill the hose with distilled water from the syringe. - Tighten the hose on the bottle. <p>If the pump does not restore performance, contact the service engineer</p>

9.2 Cleaning and disinfection.

9.2.1 Before starting the washing procedure, rinse the system with distilled water as described in section **6. Operation closedown.**

9.2.2 Use mild soap and water with a soft cloth or sponge for cleaning the exterior. Rinse remaining washing solution with distilled water. Wipe dry the excess water with clean, soft cloth or sponge, paying special attention to the guiding rail (fig. 3/1).

9.2.3 To disinfect the plastic and metal parts, especially plate platform and the flat spring in it, use 75% ethanol or DNA/RNA removing solution (e.g., Biosan PDS-250). After disinfecting, wipe the surfaces dry.

9.2.4 **Autoclaving.** Unit and its accessories are not autoclavable.

9.3 Filter replacement (figure 16).

9.3.1 Change the hydrophobic filter once every six months, in particular cases, e.g., after intensive operations, once every three months. To order the filter, look up the product's catalogue number, see **8.2.2.**

9.3.2 Disconnect the filter from outlet tube, remove the filter, insert a new filter into the socket and tighten it.



Caution! Maintain the mounting of the filter according to figure 16. The **IN** marking should be located on the side of the inlet tube (facing the bottle).

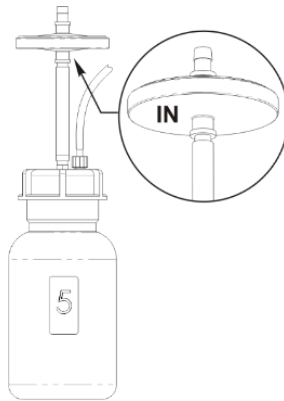

Figure 11. Filter mount

9.4 **Disposal.** Disposal of the appliance requires special precautions and must be carried out at an appropriate disposal site, separate from normal household waste. To prevent pollution of the environment, all waste resulting from the disposal of the product must be collected and disposed of in the country of use, in accordance with the applicable requirements for the handling of electronic waste.

10. Storage and transportation

- 10.1 Store and transport the unit in a horizontal position (see package label) at ambient temperatures between -20°C and +60°C and maximum relative humidity of 80%.
- 10.2 After transportation or storage and before connecting it to the electric circuit, keep the unit under room temperature for 2-3 hrs.
- 10.3 **Extended storage.** For long-term storage, keep the appliance and its accessories in their original packaging, in a dry, dust-free place. For transportation, always pack the appliance in its original packaging, regardless of whether it is to be transported by land, water or air. To pack the appliance correctly, proceed as follows:



Caution! Before transporting the unit at low temperatures, disconnect the tubes from the buffer bottles and air-dry the tubes, following steps **6.2.2–6.2.4**. It is not necessary to carry out this procedure every time you finish operation of the unit.



Caution! We do not accept warranty claims related to damages caused by improper packaging.

- 10.3.1 Remove the manifold, tubes and platform for plates.
- 10.3.2 Cover unit sides with cut-out covers and place it into the original carton box.
- 10.3.3 Place the manifold into protecting case; place syringe, manifold cleaning set and the platform into PE bag. Place the bag and the case with the manifold in the corners of the box between the packaging blocks and the side panels of the carton box; place the 2-litre bottle and the half-litre bottle in free space between the packaging blocks and the side panels of the carton box.
- 10.3.4 Insert the top section into the carton box by bending the section downwards along the perimeter and inserting the bent parts between the walls of the original carton box and packaging blocks, so that the device and the remaining content of the box are fully covered.
- 10.3.5 Put the soft foam sheet (grey) with the smooth side down on the resulting horizontal carton surface.
- 10.3.6 Put the remaining three bottles and other accessories on the foam sheet.
-  **Note.** If 4-channel weight logger is included in the kit, insert pads under scale cups, then place the logger into top section of packaging.
- 10.3.7 Cover everything with another sheet of soft foam material with the smooth side up.
- 10.3.8 Close the box and seal with packing tape.

11. Warranty

- 11.1 The Manufacturer guarantees the compliance of the unit with the requirements of Specifications, provided the Customer follows the operation, storage and transportation instructions.
- 11.2 The warranted service life of the unit from the date of its delivery to the Customer is 24 months, excluding optional accessories mentioned in the section **Ordering information**. For extended warranty, see **11.5**.
- 11.3 Warranty covers only the units transported in the original package.
- 11.4 If any manufacturing defects are discovered by the Customer, an unsatisfactory equipment report shall be compiled, certified and sent to the local distributor address. To obtain the claim form, visit **Technical support** page on our website at link below.
- 11.5 Extended warranty. For **3D-IW8**, the *Premium* class model, one year of extended warranty is available free of charge after registration, during 6 months from the date of sale. Online registration form can be found in section **Warranty registration** on our website at the link below.
- 11.6 Description of the classes of our products is available in the **Product class description** section on our website at the link below.

Technical support



biosan.lv/en/support

Registration

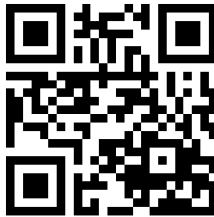

biosan.lv/register-en

Product class description



biosan.lv/classes-en

- 11.7 The following information will be required in the event that warranty or post-warranty service comes necessary. Complete the table below and retain for your record.

Model	Serial number	Date of sale
Intelwasher 3D-IW8, microplate washer		

- 11.8 **Production date.** Production date is placed in the serial number, on the label of the unit. Serial number consists of 14 digits styled XXXXXYYMMZZZZ, where XXXXXX is model code, YY and MM – year and month of production, ZZZZ – unit number.

12. EU declaration of conformity

12.1 Microplate washer **Intelispeed 3D-IW8** is in conformity with the following relevant Union legislations:

LVD 2014/35/EU	LVS EN 61010-1:2011 Safety requirements for electrical equipment for measurement, control, and laboratory use. General requirements.
EMC 2014/30/EU	LVS EN 61326-1:2013 Electrical equipment for measurement, control and laboratory use. EMC requirements. General requirements.
RoHS3 2015/863/EU	Directive on the restriction of the use of certain hazardous substances in electrical and electronic equipment.
WEEE 2012/19/EU	Directive on waste electrical and electronic equipment.

12.2 Declaration of Conformity is available for download on the page for the relevant model on our website by links below, in the **Downloads** section:



Intelispeed 3D-IW8

SIA Biosan

Ratsupites 7, k-2, Riga, LV-1067, Latvia

Phone: +371 67426137 Fax: +371 67428101

<http://www.biosan.lv>

Edition 3.03 – August of 2022